



GOVERNMENT OF PAKISTAN
(CABINET DIVISION)
INTELLECTUAL PROPERTY ORGANIZATION
THE PATENT OFFICE
KARACHI



To,

Dated:21-10-2008

Mr. Munir Ahmed,
Director (Admn.),
IPO-Pakistan,
Islamabad.

**Subject: WEEKLY NOTIFICATION OF PATENT OFFICE FOR THE
WEEKENDING 20-09-2008 TO BE PUBLISHED 22-10-2008 IN
THE GAZETTE OF PAKISTAN PART-V.**

Sir,

Reference to IPO letter dated 12-5-2008 forwarding therewith copy of letter No 18/IPO/2008/ RA-IV dated 23-4-2008 from Cabinet Division on the above subject.

A manuscript copies of the weekly notification regarding application filed, application accepted and sealing fee due is enclosed herewith for onward transmission to the Cabinet Division for Publication in the next issue of the Gazette of Pakistan (Part –V)

(Mrs. Yasmeen Abbasi)
Controller of Patents
Ph: 9215488

ENCL:

GOVERNMENT OF PAKISTAN
THE PATENT OFFICE
2nd Floor, Kandawala Building,
M.A. Jinnah Road,
Karachi

No.2/2/2003-F.Sec.

Dated: 21-10-2008

To,

Mr. Manzoor Ahmed
Section Officer
Cabinet Secretariat
Cabinet Division
Government of Pakistan
Islamabad

Subject: **WEEKLY NOTIFICATION OF PATENT OFFICE FOR THE
WEEKENDING 20-9-2008 TO BE PUBLISHED 22-10-2008 IN THE
GAZETTE OF PAKISTAN PART-V.**

Reference to Cabinet Secretariats letter No. 18/IPO/2008/RA-IV, dated 23rd April 2008. A manuscript copy of the weekly notification regarding application filed, application accepted and sealing fee due etc., is enclosed herewith for onward transmission to the Printing Corporation of Pakistan Press for publication in the next issue of the Gazette of Pakistan Part-V.

(Mrs. Yasmeen Abbasi)
Controller of Patents
Ph: 9215488

ENCL:

NEW APPLICATIONS FOR THE PATENTS

The dates shown in the crescent brackets are the dates claimed under section 86 of the Patents Ordinance 2000.

1096/2008	<u>15-9-2008</u> Bayer CropScience AG, Germany (Priority 26-9-07 Germany)	“Method for improved utilization of the production potential of transgenic plants”
1097/2008	Bayer CropScience AG, Germany (Priority 26-9-07 Germany)	“Active substance combinations with insecticidal and acaricidal properties”
1098/2008	<u>16-9-2008</u> Abbott Laboratories. USA (Priority 17-9-07 USA)	“Anti-infective agents and uses thereof”
1099/2008	N. V., Organon, Netherlands (Priority 17-9-07 Europe)	“Tricyclic heterocyclic derivatives”
1100/2008	Unilever PLC., United Kingdom (Priority 19-9-07 Europe)	”Bverage precursor and process for the manufacture thereof”
1101/2008	<u>17-9-2008</u> Boehringer Ingelheim PharmaGmbH & Co, Ltd. Germany (Priority 31-10-2001 Germany) Divisional	“A process for preparing telmisartan sodium salt and its use for preparing pharmaceutical composition”
1102/2008	Romet Limited, Canada (Priority 21-9-07 USA)	“Unidirectional clutch assembly”
1103/2008	LES Lobpratpores Servier France (Priority 26-9-07 France)	“New process for the synthesis of strontium ranelate and its hydrates”

1104/2008	Maricap OY, Finland (Priority 21-9-07 Finland)	“Waste cpmveyomg system”
1105/2008	Sefar AG, Switzerland (Priority 17-9-07 Germany)	“Sieve starap for a stretch work of a spider machine as well as stretch device with a sieve strap”
	<u>18-9-2008</u>	
1106/2008	Huawei Technologies Co., Ltd. P.R. China (Priority 19-9-07 China)	“Method, system and device for processing information by multimedia contact center”
1107/2008	Green Source Energy LLC, USA (Priority 20-9-07 USA)	“Extraction of hydrocarbons from hydrocarbon-containing materials”
1108/2009	H. Lundbeck A/S. Denmark (Priority 19-9-07 Denmark)	“Cyanoisoquinoline”
1109/2008	Huawei Technologies Co., Ltd. .China (Priority 18-9-07 China)	“Method, system and device for network multimedia conference access”
1110/200	Glaxo Group Limited, United Kingdom (Priority 20-9-07 GB)	“Compounds which have activity at M ₁ receptor and their uses in medicine”
1111/2008	Honda Motor Co., Ltd. Japan (Priority 29-9-07 Japan)	“Small vehicle”
1112/2008	Novartis AG, Switzerland (Priority 20-9-07 USA)	“Lyophilized pharmaceutical compostions”
1113/2008	Janssen Pharmaceutica N.V., Belgium (Priority 21-9-07 Europe)	“Inhibitors of the interaction between MDM2 and p53”

	<u>19-9-2008</u>	
1114/2008	Douglas C. Comrie, USA (Priority 19-9-07 US)	“Methods and devices for reducing hazardous air pollutants”
1115/2008	Merck Co., Inc. USA (Priority 27-9-07 USA)	“Compounds and methods for leukotriene biosyntheses inhibitor”
1116/2008	Sanofi-Aventis France (Priority 21-9-07 Europe)	“Carbocyclohexenylphenyl)phenyloxamides, process for their preparation and their use as medicaments”
1117/2008	Sanofi-Aventis France (Priority 21-9-07 Europe)	“Carbocyclohexenylphenyl)phenyloxamides, process for their preparation and their use as medicaments”
	<u>20-9-2008</u>	
1118/2008	1. Dr. Saima Rahman, 2. Ammara Hassan, 3. Afsheen Arshad PCSIR, Lahore	“ A process for the preparation of herbal antiscabies lotion composition”
1119/2008	IRM LLC., Bermuda (Priority 20-9-07 USA)	“Compounds and compositions as modulators of GPR119 activity”
1120/2008	DyStar Textilfarben GMBH & Co., Deutschland KG, Germany (Priority 22-9-07 Germany)	Azo dyes for dyeing and printing hydrophobic materials”
1121/2008	N. V., Organon, Netherlands (Priority 21-9-07 Europe)	“Drug delivery system”
1122/2008	Wyeth, USA (Priority 21-9-07 USA)	“Chiral synthesis of diazepinoquinolines”

XXXXXXXXXXXX

APPLICATION ACCEPTED

Notice is hereby given that the person interested in opposing the grant of Patents to any of the applications referred to below at any time within four months from the date of this Gazette may give notice at the Patent Office on the prescribed Form P-7 of the Patents Rules 18(1) of 2003.

The six figures number shown in the right hand side are those given to applications on acceptance of the complete specification under which the specification will be printed and subsequent proceeding taken.

The figures shown within square brackets after the title of inventions indicate their classification index at acceptance.

Typed copies of the specification which are to open to public inspection can be supplied by the Patent Office on payment of the prescribed charges which may be ascertained on application to the office.

579/2000	Janssen Pharmaceutica N.V., Belgium	“Imidazopyridine compound” (CO7D, 233/64, A61K, 31/415)
----------	--	--

139800

This invention concerns a compound of formula

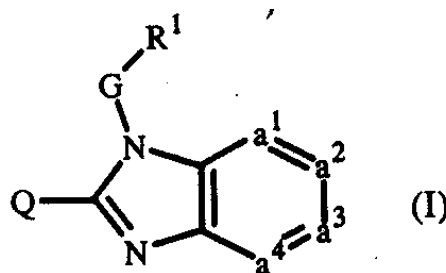

prodrug, N-oxide, quaternary amine, metal complex or stereochemically isomeric form thereof wherein -(a)1=(a)2-(a)3=(a)4- is a radical of formula -CH=CH-CH=CH-, -N=CH-CH=CH-, -CH=N-CH=CH-, -CH=CH-N=CH-, -CH=CH-CH=N- wherein each hydrogen atom may optionally be substituted; Q is a radical of formula

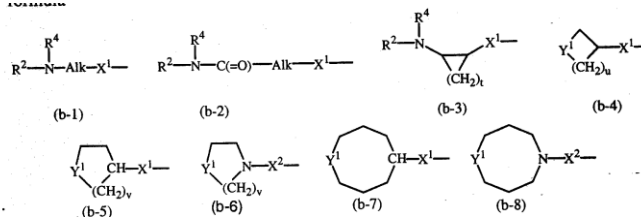

wherein Alk is (C)1-6alkanediyl; Y is a bivalent radical of formula -MR - or -CH(NR)2(R)4-; (X)1 is (NR)4, S, S(=O), S(=O)2 O, (CH)2, C(=O), CH(=CH)2, CH(OH), CH(CH)3, CH(OCH)3, CH(SCH)3, CH(NR)5a(R)5b, (CH)2-(NR)4 or (NR)4-(CH)2; (X)2 is a direct bond, (CH)2, C(=O), (NR)4, (C)1-4alkyl-(NR)4, (NR)4-(C)1-4alkyl; t is 2 to 5; u is 1 to 5; v is 2 or 3; and whereby each hydrogen in Alk and in (b-3), (b-4), (b-5), (b-6), (b-7) and (b-8), may optionally be replaced by (R)3; provided that when (R)3 is hydroxy or (C)1-6alkyloxy, then (R)3 can not replace a hydrogen atom in the Alpha position relative to a nitrogen atom; G is substituted (C)1-10alkanediyl wherein the substituent is attached via an oxygen atom; (R)1 is an optionally substituted monocyclic heterocycle or aryl; (R)2 is hydrogen, formyl, (C)1-6 alkylcarbonyl, Hetcarbonyl, pyrrolidinyl, piperidinyl, homopiperidinyl, (C)3-7cycloalkyl or (C)1-10alkyl substituted with N(R)6)2 and optionally with another substituent; (R)3 is hydrogen, hydroxy, (C)1-6alkyl, (C)1-6alkyloxy, aryl-d-ealkyl or aryl(C)1-6alkyloxy; (R)4 is hydrogen, (C)1-6alkyl or aryl(C)1-6alkyl; (R)5a, (R)5b, (R)5c and (R)5d are hydrogen or (C)1-6alkyl; or (R)5a and (R)5b, or (R)5c and (R)5d taken together from a bivalent radical of formula -(CH)2)s-wherein s is 4 or 5;(R)6 is hydrogen, (C)1-4alkyl, formyl, hydroxyl(C)1-6alkyl, (C)1-6alkylcarbonyl or (C)1-6alkyloxycarbonyl; aryl is optionally substituted phenyl; the treatment of viral infections, in particular RSV infections.

564/2005 Les
Laboratoires
Servier,
France

“Alpha Crystalline form of strontium ranelate”

(CO7D, 333/20)

139801

Alpha crystalline form of strontium ranelate of formula (I):

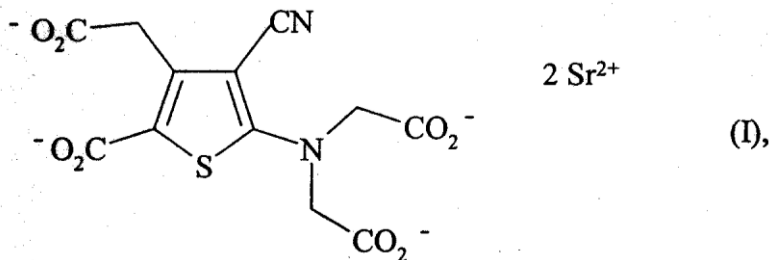

Characterized by its powder X-ray diffraction diagram and by a water content of from 22 to 24% to its pharmaceutical composition.

1065/2005 Groz-Beckert "Shaft rod for heald shafts"
 KG.,
 Germany (D03C, 9/06)

139802

A shaft rod (2) according to the invention has, particularly in its mid region, a particularly low mass. The shaft rod has an upper ledge (11) and a lower ledge (12) which have a reduced thickness in the mid region of the shaft rod. As a result, the load induced by acceleration forces is significantly less in the mid region than in conventional constructions. By virtue of the reduced acceleration forces, the extent of bending of the shaft rods in the middle is less and therefore a shaft rod of such a structure is better adapted for use in very rapidly operating weaving machines.

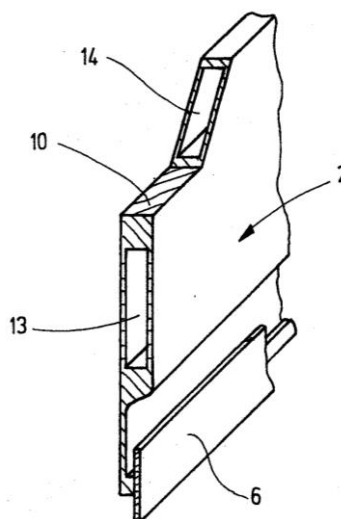

Fig.3

291/2006 1.Dr. S.M.
Saqlan Naqvi.
2.Dr. Tariq
Mahmood.
University of
Arid
Agriculture,
Rawalpindi,
Pakistan.

“Regulating genes under stress condition “

(AO1H, 5/00)

139803

Germin and germin-Hke proteins (GLPs) are water soluble extracellular proteins, reportedly expressed under stress conditions due to different environmental and developmental conditions. Different enzymatic activities have been associated with these proteins, however their significant role in overall metabolism has not been well understood yet. It has been suggested that germin and GLPs are stress responsive gene products. One approach to establish their involvement in stress-tolerance is either to study their expression or to study the ability of their promoter regions to derive expression of some reporter gene during stress. This study was designed to clone about 1100 base pairs (bp) 5' region of *Oryza sativa* root GLP 2 gene (OsRGLP2), sequencing it and identification of different transcriptional/regulatory elements. The sequence analysis showed that this promoter sequence has five common regions (CR1-CR5) of different sizes which are repeated at 3-5 other locations in 30 Kb region of *Oryza sativa* chromosome 8, OsRGLP1 was also present in this region. Interestingly all the genes driven by these promoter regions are GLPs/putative germins and they are clustered in this 30 Kb region. Regulatory elements analysis of these common regions located on OsRGLP2 indicated the presence of many elements including elements for light responsive, dehydration and dark induced senescence, stress (pathogen and salt), plant growth regulators, pollen specific expression and elements related to seed storage proteins. Further analysis of this germin/GLP clustered demonstrated that each gene has a putative 40 bp promoter which is a part of CR2 and contains TATA box and CTCC element. We are therefore, making transgenic plants containing GUS gene under the influence of different sizes of OsRGLP2 promoter region. These plants will be analyzed for the role of these putative promoter elements, during the developmental/environmental conditions in which their role is reported in literature.



SEALING FEES DUE

Notice is hereby given that the Patent may now be sealed on the application referred to below if it is desired that Patent should be sealed a request on the prescribed Form-10 accompanied by the fee of Rs.2250/- should be sent to the Controller of Patents and Designs, The Patent Office, Karachi.

139426	Jassen Pharmaceutica N.V., Belgium	397/1997
139427	Jassen Pharmaceutica N.V., Belgium	400/1997
139428	Wyeth Holdings Corporation, USA.	1052/2001
139429	Almirall Prodesfarma, S.A., Spain	1209/2001
139430	Aventis CropScience GmbH, Germany	408/2002
139431	Wyeth, USA.	1022/2002
139432	AstraZeneca AB, Sweden	1030/2002
139433	Honda Motor Co. Ltd., Japan	40/1999
139434	Zimmer AG, Germany	143/2005
139435	Janssen Pharmaceutica N.V. Belgium	182/2005
139436	Meiji Dairies Corporation, Japan	613/2005
139437	Sanofi-Aventis, France	654/2005
139438	Wyeth, USA	979/2006

(MRS. YASMEEN ABBASI)
CONTROLLER OF PATENTS
Tel: 921548