



GOVERNMENT OF PAKISTAN  
(CABINET DIVISION)  
INTELLECTUAL PROPERTY ORGANIZATION  
THE PATENT OFFICE  
**KARACHI**



To,

Dated: 19-12-2008

Mr. Munir Ahmed,  
Director (Admn.),  
IPO-Pakistan,  
**Islamabad.**

**Subject: WEEKLY NOTIFICATION OF PATENT OFFICE FOR THE WEEKENDING 06-12-2008 TO BE PUBLISHED 20-12-2008 IN THE GAZETTE OF PAKISTAN PART-V.**

Sir,

Reference to IPO letter dated 12-5-2008 forwarding therewith copy of letter No 18/IPO/2008/ RA-IV dated 23-4-2008 from Cabinet Division on the above subject.

A manuscript copies of the weekly notification regarding application filed, application accepted and sealing fee due is enclosed herewith for onward transmission to the Cabinet Division for Publication in the next issue of the Gazette of Pakistan (Part –V)

**(Mrs. Yasmeen Abbasi)**  
Controller of Patents  
Ph: 9215488

**ENCL:**

**GOVERNMENT OF PAKISTAN**  
**THE PATENT OFFICE**  
2nd Floor, Kandawala Building,  
M.A. Jinnah Road,  
**Karachi**

No.2/2/2003-F.Sec.

Dated: 19-12-2008

To,

Mr. Manzoor Ahmed  
Section Officer  
Cabinet Secretariat  
Cabinet Division  
Government of Pakistan  
Islamabad

Subject: **WEEKLY NOTIFICATION OF PATENT OFFICE FOR THE  
WEEKENDING 06-12-2008 TO BE PUBLISHED 20-12-2008 IN THE  
GAZETTE OF PAKISTAN PART-V.**

Reference to Cabinet Secretariats letter No. 18/IPO/2008/RA-IV, dated 23<sup>rd</sup> April 2008. A manuscript copy of the weekly notification regarding application filed, application accepted and sealing fee due etc., is enclosed herewith for onward transmission to the Printing Corporation of Pakistan Press for publication in the next issue of the Gazette of Pakistan Part-V.

**(Mrs. Yasmeen Abbasi)**  
Controller of Patents  
Ph: 9215488

ENCL:

## NEW APPLICATIONS FOR THE PATENTS

The dates shown in the crescent brackets are the dates claimed under section 86 of the Patents Ordinance 2000

	<b><u>01-12-2008</u></b>	
1413/2008	Boehringer Ingelheim International GmbH, Germany (Priority 03-12-07 Europe)	“Indolinone derivatives and process for their manufacture”
1414/2008	SmithKline Beecham Corporation USA (Priority 03-12-07 GB)	“Compounds”
	<b><u>02-12-2008</u></b>	
1415/2008	Takeda Pharmaceutical Company Limited, Japan (Priority 03-12-07 USA)	“Nitrogen-containing heterocyclic compound and use thereof”
1416/2008	Eli Lilly and Company, USA (Priority 20-9-06 USA) <b>Divisional</b>	“3-[4-bromo-2-(2-methyl-2H-[1,2,4] triazol-3-yl)-thiazol-5yl]2,dimethyl-7-(1-propyl-butyl) pyrazolo[1, 5,-a] pyrimidine compound”
1417/2008	Eli Lilly and Company, USA (Priority 20-9-06 USA) <b>Divisional</b>	“3-[4-bromo-2-(2-methyl-2H-[1,2,4] triazol-3-yl)-thiazol-5yl]-7-(1-ethyl-propyl) -2, 5- dimethyl - pyrazolo[1, 5,-a] pyrimidine compound”
1418/2008	Eli Lilly and Company, USA (Priority 20-9-06 USA) <b>Divisional</b>	“3-[4-chloro-2-morpholin-4-yl-thiazol-5-yl) -7-(1-ethyl-propyl) -2, 5- dimethyl -pyrazolo[1, 5,-a] pyrimidine compound”
1419/2008	CoolTech Applications France (Priority 04-12-07 France)	“Magnetocaloric generator”
1420/2008	Bangkok Synthetics Co., Ltd. Thailand (Priority 07-12-07 USA)	“Alternative crosslinking technology”

	<b>03-12-2008</b>	
1421/2008	Farkhanda Ghafoor NHRC Lahore	“Enzyme immunoassay for glycated haemoglobin (HbA1c)”
1422/2008	Eli Lilly and Company USA (Priority 09-4-08 USA)	“Mineralocorticoid receptor antagonists and methods of use”
	<b>04-12-2008</b>	
1423/2008	JSC Grindeks Latvia (Priority 04-12-07 Europe)	“New medical use of 3-(2,2,2-trimethylhydrazinium) propionate salts”
1424/2008	JSC Grindeks Latvia (Priority 5-12-07 Europe)	“New medical use of 3-(2,2,2-trimethylhydrazinium) propionate salts”
1425/2008	1.Linde AG, Germany 2.Saudi Basic Industries Corporation, Saudi Arabia (Priority 06-12-07 Europe)	“Catalyst composition and process for preparing linear alpha-olefins”
1426/2008	GlaxoSmithKline Biologicals S.A., Belgium (Priority 06-12-07 USA)	“VACCINE”
1427/2008	Tibotec Pharmaceuticals Ltd., Ireland (Priority 06-12-07 Europe)	“Amide compounds as boosters of antivirals”
1428/2008	Schering Corporation, USA (Priority 07-12-07 USA)	“Gama Secretase modulators”
1429/2008	Eli Lilly and Company USA (Priority 20-11-06 USA) <b>Divisional</b>	“A pharmaceutically acceptable salt of a tetrahydrocyclopenta [b] indole compound”
1430/2008	AstraZeneca AB, Sweden (Priority 12-12-07 USA)	“Novel compounds 010”

	<b>05-12-2008</b>	
1431/2008	Adisseo France S.A.S., France (Priority 05-12-07 USA)	“Biocarburant preparation using penicillium funiculosum enzymes”
	<b>06-12-2008</b>	
1432/2008	Dr. Mansoor Ahmed University of Karachi	“Sexual lubricants containing sodium as an antiviral agent”
1433/2008	Novartis AG, Switzerland (Priority 10-12-07 Europe)	“Organic compounds”
1434/2008	Bayer Animal Health GmbH Germany (Priority 19-12-07 Germany)	“Novel use of amidine derivatives”
1435/2008	Bayer Technology Services GmbH Germany (Priority 19-12-07 Germany)	“Process for the preparation of fatty acid alkyl esters”
1436/2008	Bayer HealthCare AG Germany (Priority 13-12-07 Germany)	“Triazolotriazines and triazolopyrazines and their use”
1437/2008	Glaxo Group Limited, United Kingdom (Priority 11-12-07 GB)	“Antigen binding proteins”
1438/2008	Urea Casale S.A., Switzerland (Priority 12-12-07 Europe)	“Vibrating prilling bucket for granulation of a fluid substance”
1439/2008	Methanol Casale S.A Switzerland (Priority 11-12-07 Europe)	“Supporting system of heatexchange plates in isothermal chemical reactors”
1440/2008	Bayer Schering Pharma Aktiengesellschaft Germany (Priority 10-12-07 Germany)	“Functionalized, solid polymer nanoparticles comprising epothilones”

1441/2008	Mr. Afzaal Mustafa Islamabad	“Programmable multiple tank geyser and its operating system through controller for Gas Conservation”
-----------	---------------------------------	---------------------------------------------------------------------------------------------------------------



## APPLICATION ACCEPTED

Notice is hereby given that the person interested in opposing the grant of Patents to any of the applications referred to below at any time within four months from the date of this Gazette may give notice at the Patent Office on the prescribed Form P-7 of the Patents Rules 18(1) of 2003.

The six figures number shown in the right hand side are those given to applications on acceptance of the complete specification under which the specification will be printed and subsequent proceeding taken.

The figures shown within square brackets after the title of inventions indicate their classification index at acceptance.

Typed copies of the specification which are to open to public inspection can be supplied by the Patent Office on payment of the prescribed charges which may be ascertained on application to the office.

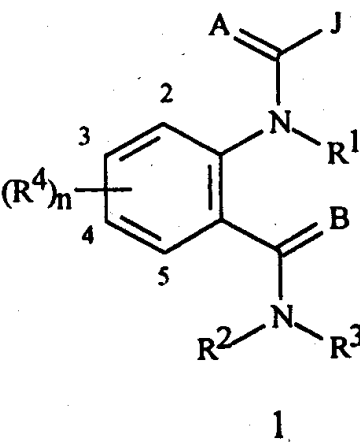
234/2001	E.I. DU Pont DE Nemours and Company, USA.	<p>“An anthranilamide compound”</p> <p>(A01N, 43/54)</p> <p style="text-align: right;"><b>139884</b></p> <p>This invention provides compound of Formula 1, its N-oxide.</p> <div style="text-align: center;">  <p style="text-align: center;">1</p> </div> <p>Wherein A, B, J, R<sup>1</sup>, R<sup>2</sup>, R<sup>3</sup> and R<sup>4</sup> and n are as defined in the disclosure.</p> <p>Also disclosed are methods for controlling arthropods comprising contacting the arthropods or their environment with an arthropodically effective amount of a compound Formula 1 and composition containing the compound of Formula</p>
----------	-------------------------------------------	-----------------------------------------------------------------------------------------------------------------------------------------------------------------------------------------------------------------------------------------------------------------------------------------------------------------------------------------------------------------------------------------------------------------------------------------------------------------------------------------------------------------------------------------------------------------------------------------------------------------------------------------------------------------------------------------------------------------------------

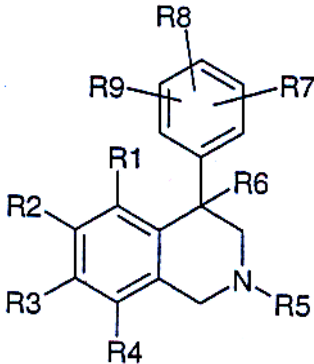
		1.
98/2004	Sanofi-Aventis Deutschland GmbH, Germany	<p>“Substituted 4-phenyltetrahydroisoquinoline compound”</p> <p>(CO7D, 413/02)</p> <p style="text-align: right;"><b>139885</b></p> <p>The invention relates to compound of the formula I</p> <div style="text-align: center;">  <p style="text-align: right;">I</p> </div> <p>Where R1 to R9 are each as defined in the specification. Medicament which comprise compound of this type are useful in the prevention or treatment of various disorders. For instance, the compound can be used, among other uses, in the event of disorders of biliary function, in the event of respiratory disorders such as snoring or sleep apneas or in the event of stroke.</p>

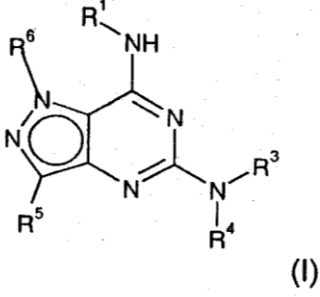
940/2004	Pfizer Inc., USA.	<p>“5,7-diaminopyrazolo [4,3-] pyrimidine”</p> <p>(CO7D, 487/04)</p> <p style="text-align: right;"><b>139886</b></p> <p>This invention relates to compound of formula (I)</p> <div style="text-align: center;">  <p>(I)</p> </div> <p>Wherein</p> <p>R<sup>1</sup> as a pyridyl optionally substituted with one or more C<sub>1</sub>-C<sub>6</sub> alkyl groups;</p> <p>R<sup>3</sup> and R<sup>4</sup> are each independently hydrogen or C<sub>1</sub>-C<sub>6</sub> alkyl;</p> <p>R<sup>5</sup> is CONHR<sup>18</sup>;</p> <p>R<sup>6</sup> is C<sub>1</sub>-C<sub>6</sub> alkyl, optionally substituted by a substituent selected from -OH, C<sub>3</sub>-C cycloalkoxy, C<sub>1</sub>-C<sub>6</sub> alkoxy and C<sub>1</sub>-C<sub>6</sub> haloalkoxy;</p> <p>R<sup>18</sup> is selected from the group consisting of SO<sub>2</sub>-(C<sub>1</sub>-C<sub>6</sub> alkyl) and -SO<sub>2</sub>-phenyl.</p>
1058/2005	ENI S.P.A., Italy	<p>“A porous bed centrifuge for the continuous separation of immiscible liquids”</p> <p>(BO4B, 1/08, BO1D, 17/02)</p> <p style="text-align: right;"><b>139887</b></p> <p>Porous bed centrifuge for the continuous separation of immiscible liquids, which comprises:</p> <ol style="list-style-type: none"> <li>a) a first outer compact essentially conical-shaped rotating skirt;</li> <li>b) a second inner compact essentially conical-shaped skirt, integral with the outer skirt and positioned so as to form an interspace with said outer skirt;</li> <li>c) a perforated toroidal-shaped separation element positioned at the base of the two skirts and suitable for separating the</li> </ol>

		<p>interspace from the inside of the centrifuge;</p> <p>d) a closing base integral with the outer skirt by means of a sealing gasket;</p> <p>e) a section, equipped with a weir acting as a flow regulator, fixed at the head of the outer skirt and with openings for the discharge of the separated liquids;</p> <p>f) a first coaxial tube, integral with the outer skirt and with section(e);</p> <p>g) a second coaxial tube with is not integral with the outer skirt, positioned inside the first tube, for the feeding of the dispersion;</p> <p>h) a filling in the form of particles capable of filling from 40 to 70% of the inner volume of the centrifuge.</p>
7/2006	Raytheon Company, USA.	<p>“Programmable cockpit upgrade system”</p> <p>(GO1C, 23/00)</p> <p style="text-align: right;"><b>139888</b></p> <p>Disclosed is a programmable computing and display device (14) for upgrading a cockpit instrument panel (12) of an air craft (8). The programmable computing and display device includes a plurality of processing units; a network backbone (50) that establishes a network among the processing units for the exchange of network data traffic; at least one display (16) to display video graphics to a cockpit crew member; and a modular assembly (17) that retains the processing units, the network backbone and the display.</p>
225/2007	Honda Motor Co., Ltd., Japan	<p>“Improved transmission mechanism for a motorcycle”</p> <p>(F16H, 63/14)</p> <p style="text-align: right;"><b>139889</b></p> <p>In a change mechanism of transmission, a plurality of driven pins 15, provided at an end portion of a shift drum 2, are arranged around the axis of the shift drum 2. A change spindle 20 is made to operate in conjunction with a shift arm 25 which has a pair of drive pawls 27 facing each other with two of the driven pins 15 placed in between, the two driven pins 15 being adjacent to each other. When the shift arm 25 moves outwards, one of the drive</p>

pawls 27 feeds the corresponding one of the driven pins 15, and thus the shift drum 2 is caused to rotate by a predetermined unit angle. In this change mechanism of transmission, each drive pawl 27, rotatably supported to the shift arm 25, can move between a standing position A, where the drive pawl 27 stands up against the driven pin 15, and a receding position B, where the drive pawl 27 recedes from the driven pin 15. A standing spring 30 is connected to the drive pawls 27. When the shift arm returns, one of the drive pawls 27 is caused to recede to the receding position B by the corresponding driven pin 15 touching a rear face 27r of the drive pawl 27.

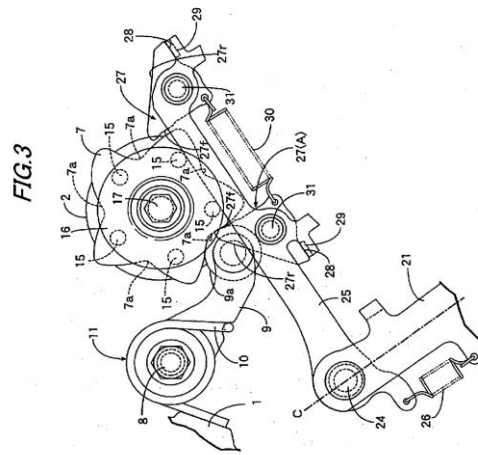

XXXXXXXXXX

## **CORRIGENDUM**

In the Gazette of Pakistan Part V, the office have issued two notifications vide dated **17-04-2008** and **27-08-2008** respectively, under the heading “**APPLICATION ACCPETED**”. The following applications have been withdraw voluntarily as per request of the applicant.

<b>S. No.</b>	<b>Application No.</b>	<b>Accepted No.</b>
1	452/1996	139452
2	811/1996	139667
3	199/2007	139688

**SEALING FEES DUE**

Notice is hereby given that the Patent may now be sealed on the application referred to below if it is desired that Patent should be sealed a request on the prescribed Form-10 accompanied by the fee of Rs.2250/- should be sent to the Controller of Patents and Designs, The Patent Office, Karachi.

139539	Boehringer Ingelheim Pharma GmbH & Co., KG. Germany	469/2002
139540	Warner-Lambert Company LLC., USA	23/2003
139541	Janssen Pharmaceutica N.V. Belgium	343/2004
139542	Pfizer Products Inc., USA	616/2004
139543	The Procter & Gamble Company., USA	336/2005
139544	Janssen Pharmaceutica N.V. Belgium	995/2006

**(MRS. YASMEEN ABBASI)**  
**CONTROLLER OF PATENTS**  
Tel: 9215488